

Product introduction

Description

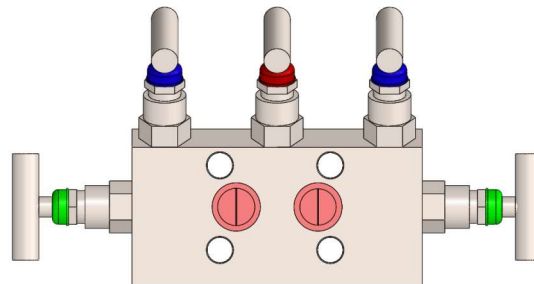

FZ50

FZ50 valve manifolds are mainly used for input signal switching on and switching off, pressure balance and discharge operation of pressure/differential pressure transmitters, convenient for instruments installation, maintenance and inspection. FZ50 valve manifolds are widely used in industries of petroleum, chemical, metallurgical, power, liquid, natural gas and various of conveying pipelines.

Main parameters

| | |
|---------------------|-----------------------------------------------------------------------------------------------------------------------------------------|
| Safety shotpin | Adopting stainless steel pin to prevent the valve seat out off the valve body due to vibration |
| Valve body design | Integral structure, firm and reliable. |
| Valve seat seal | Stainless steel seal, safe and reliable. |
| Valve spool | High-performance duplex stainless steel and spherical positioning function to improve sealing performance and service life of the valve |
| Lubricating grease | Imported grease used between the sealing gasket and adjusting screw to reduce friction and improve sealing performance. |
| Material | SUS316, SUS304, Monel, Hastelloy C |
| Marked cover | Green, red, blue mark for pressure-leading valve, balance valve, draining valve respectively |
| Stuffing box filler | PTFE |
| Working pressure | 32MPa, 42MPa |
| Working temperature | ≤150°C |
| Ambient temperature | -30°C-+93°C |

Product introduction

Structure features

Structure features of valve

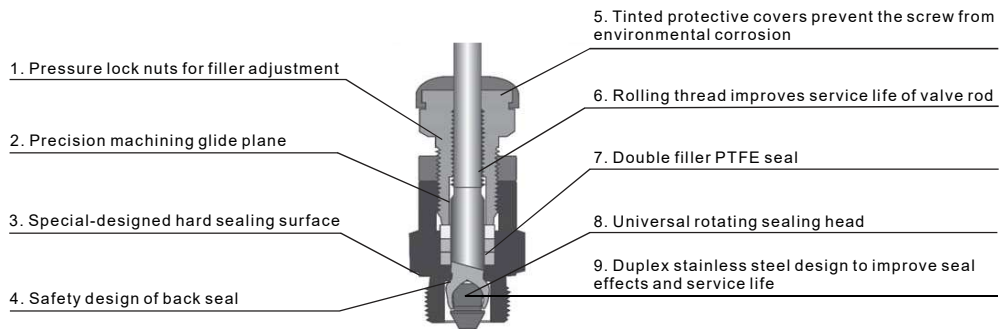

Structure features of valve spool

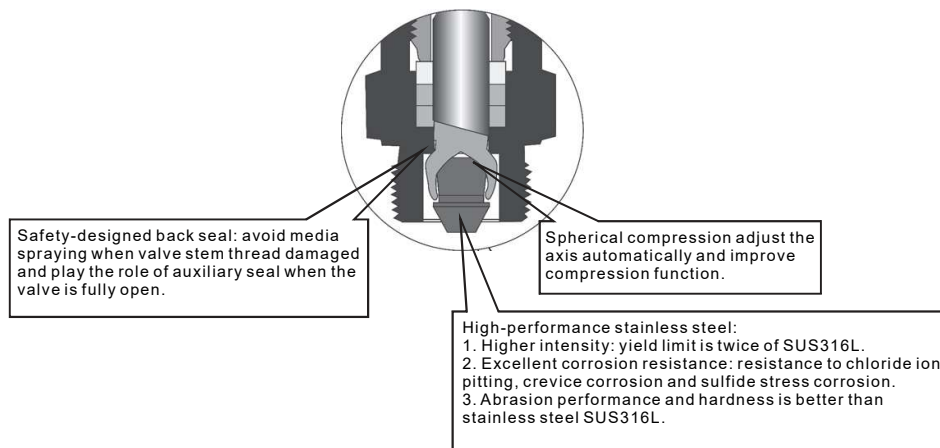

Product introduction

Pressure-temperature curve

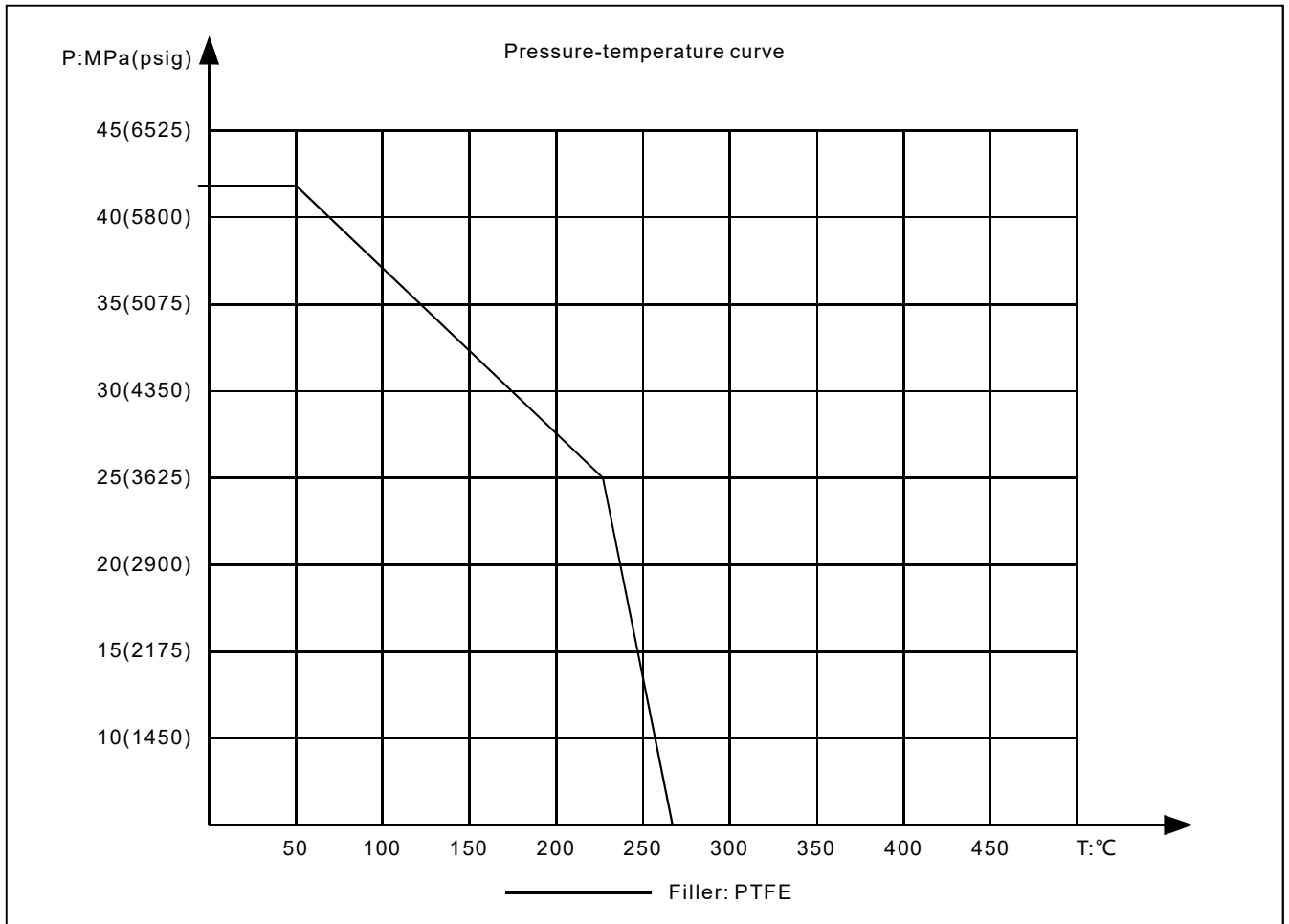

FZ50 five-valve manifold

Five-valve manifold is matched with intelligent pressure transmitters, the function is leading signal from the input-pressure point to the positive and negative measurement chamber of differential pressure transmitter and make them connected or disconnected, including two isolated stop valves, two testing drain valves and a balance valve. Applied two isolated stop valves and two testing drain valves, convenient to isolate (or close), balance and test (or drain) while differential pressure transmitter working.

Dimension

Hole center distance between valve body two ends(Instruments & mechanical side)(Unit: mm)

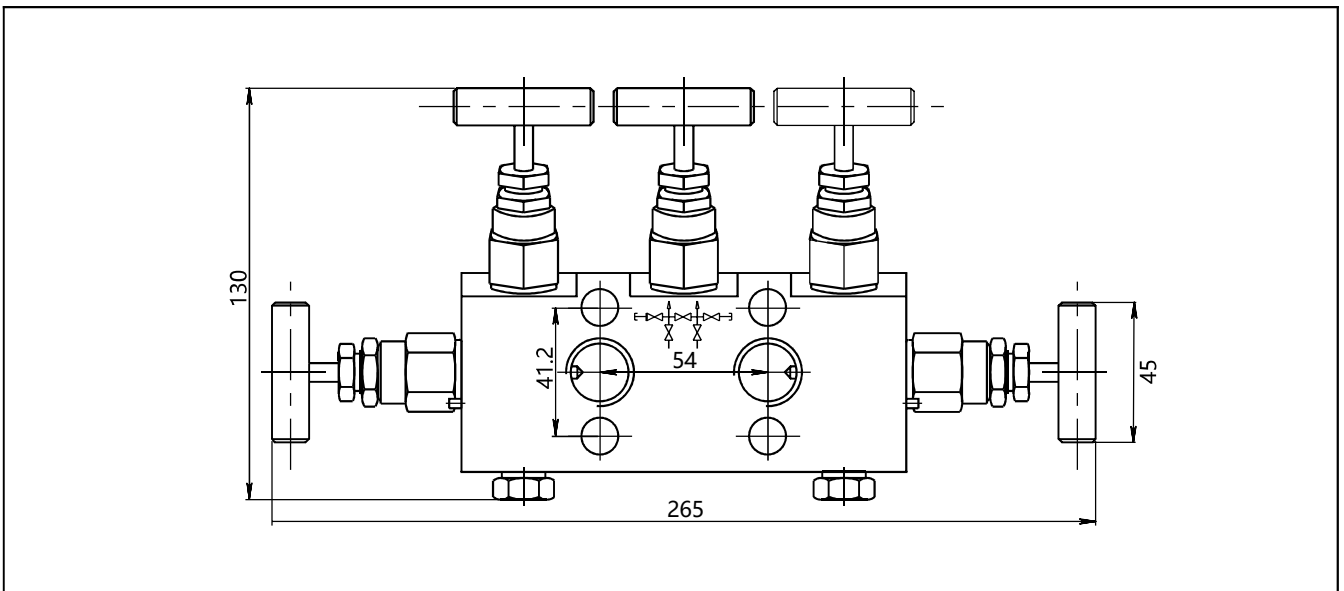

Ordering information chapter

0 =Provide - = Not provide

| FZ | Code | Code description | |
|--------------------------------------------------------------------------------|-----------|---------------------------------------------------|-----------|
| Types | 50 | 5-valve Manifold | O |
| Separator | - | Detailed specifications as following | |
| Material | 4 | 304 stainless steel | O |
| | 6 | 316 stainless steel | O |
| | Y1 | Customer | Discussed |
| Mechanical connection | N | 1/2-14NPT(F) | O |
| | J | M20*1.5(M) | O |
| | C12 | M20*1.5(M)with rear welding guiding pressure tube | O |
| | Y2 | Customer | Discussed |
| Hole center distance between valve body two ends (Instruments side) | A | Standard 54mm | O |
| | Y3 | Customer | Discussed |
| Hole center distance between valve body two ends (Mechanical connection side) | S | Standard 54mm | O |
| | Y4 | Customer | Discussed |
| Special requirement | Y5 | Special explain | Discussed |
| Example | FZ50-4NAS | | |



Shanghai LEEG Instruments Co.,Ltd

ADD: No.100 Duhui Road, Minhang District, Shanghai China
 Postcode: 201109
 Tel: (86) 21-31261976
 Fax: (86) 21-31261975
 E-mail: sales@leegsensor.com info@leegsensor.com
 Web: www.leegsensor.com



scan & follow LEEG wechat



check website for more info

Disclaimer: all the data used in the product description is not legally binding. Relevant technical details may be changed due to further improve